

RECOMMENDED PCB LAYOUT
TOLERANCES: ±0.05

- NOTE:
- MATERIAL:
 - INSULATOR: HIGH TEMPERATURE PLASTIC
 - CONTACT: BRONZE,
 - SHELL: BRASS,
 - ELECTRICAL CHARACTERISTICS:
 - CONTACT RESISTANCE: 30mΩ MAXIMUM
 - CONTACT CURRENT RATING: 1.5A
 - DIELECTRIC WITHSTANDING VOLTAGE: 100 V AC R. M. S.
 - INSULATION RESISTANCE 100 MEGOHMS MIN
 - OPERATING TEMPERATURE: -40° C ~ 85° C
 - MECHANICAL CHARACTERISTICS:
 - MATING FORCE: 3.57kgf MAX
 - UNMATED FORCE: 0.82kgf MIN AFTER TEST
 - DURABILITY MANDATORY: 1,500 CYCLES
 - Salt Spray: 24 hours

UAB0003-XXX
000: 铜壳
001: 不锈钢201

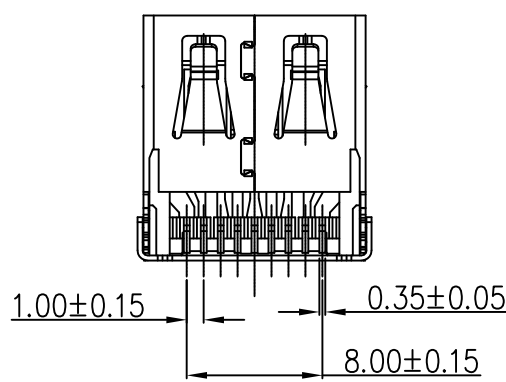

Pin NUMBER	SIGNAL NAME
1	VBUS
2	D-
3	D+
4	GND
5	StdA_SSRX-
6	StdA_SSRX+
7	GND_DRAIN
8	StdA_SSTX-
9	StdA_SSTX+
Shell	Shield

NO.	PART NAME	MATERIAL	DESCRIPTION
3	外壳	C2680/不锈钢201	GOLD/NICKEL PLATED
2	端子	C5191	GOLD/TIN PLATED
1	胶芯	BLUE LCP	UL 94V-0

HE 东莞市旭明电子有限公司				
TITLE:	USB 3.0 A/F 板上SMT H7.0短体L=14.45 无卷边 鱼叉脚			
PART NO.	UAB0003-000	CUSTOMER NO(REV)	1G	UNIT: mm
FILE NAME	180711-01	SHEET: 1 of 1	SCALE: 1:1	A4

REV	DATE	DESCRIPTION	NAME	APPRO.	GENERAL TOLERANCE UNLESS OTHERWISE NOTED	DESIGN	CHECK	APPRO.
0	18'/07/11	NEW	Wyl	Dave	0 ±0.25 0.0 ±0.20 0.00 ±0.15			